

# INSTRUCTION MANUAL



**KEPCO** An ISO 9001 Company.

**KIT  
DIN RKW  
-100S**

## DIN-RAIL MOUNTING KIT FOR SERIES RKW 100W

**DESCRIPTION.** Kepco KIT, Model DIN RKW-100S contains a cover, a preassembled mounting bracket with left and right mounting clips, and associated hardware (see Table 1) used to install RKW Series 100W power supplies on a DIN rail. The "S" suffix is for mounting along the short dimension (width) as shown in Figure 1. Outline dimensions are shown in Figure 4.

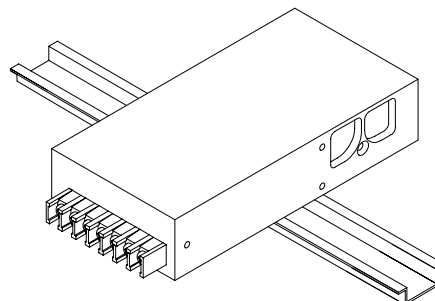

3042767

**FIGURE 1. S SUFFIX ORIENTATION**

**TABLE 1. COMPONENTS SUPPLIED**

KIT MODEL NO.	COVER PART NO.	CLIP (QTY 2) PART NO.	BRACKET (QTY 1) PART NO.	SCREW (QTY 2) PART NO.	WASHER (QTY 2) PART NO.
DIN RKW-100S	CA 35	108-0362	128-2127	501-0075 (M4 x 8MM ST.)	103-0017 (NO. 8, INT. TOOTH)

NOTE: Clips are supplied preassembled on mounting bracket. To replace a mounting clip order the clip and bracket and assemble per Figure 3 detail.

### INSTALLATION

- INSTALL COVER.** Attach the cover to the power supply per Instruction Manual supplied with the cover.
- INSTALL MOUNTING BRACKET WITH CLIPS.** Attach mounting bracket to power supply using hardware supplied (see Figure 3).

#### A INSTALLATION

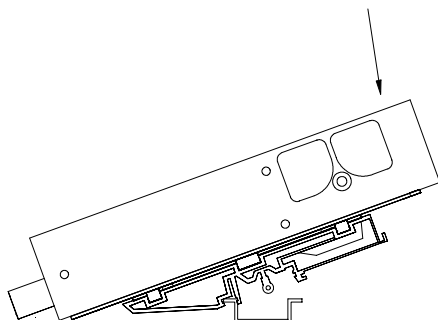

3042769

#### B REMOVAL

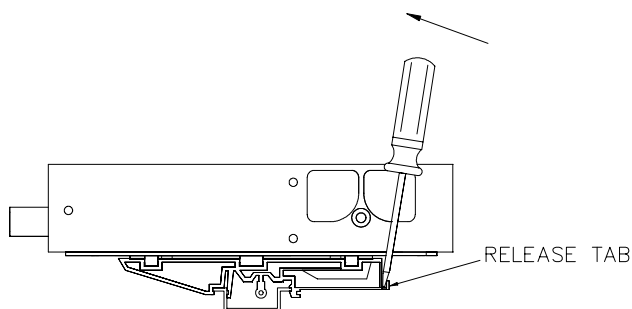
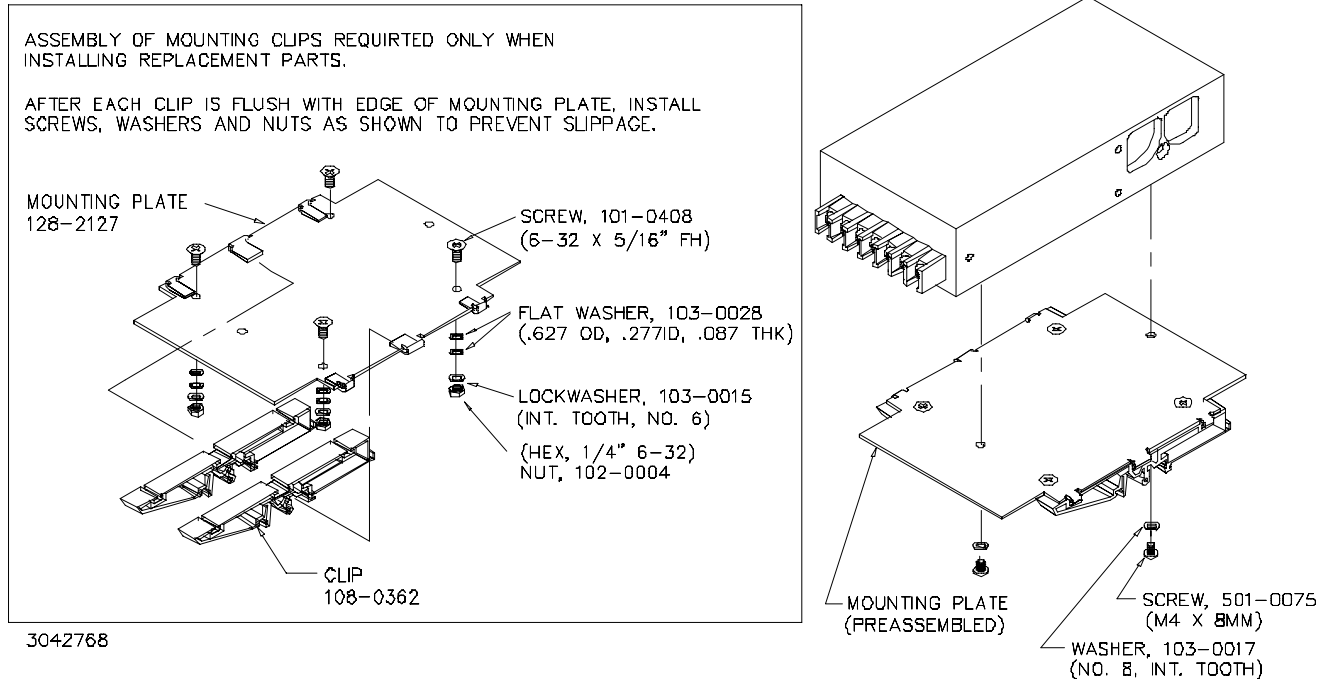

**FIGURE 2. INSTALLATION AND REMOVAL OF POWER SUPPLY FROM DIN RAIL**

KEPCO, INC. ● 131-38 SANFORD AVENUE ● FLUSHING, NY. 11352 U.S.A. ● TEL (718) 461-7000 ● FAX (718) 767-1102  
<http://www.kepcopower.com> ● email: [hq@kepcopower.com](mailto:hq@kepcopower.com)

3. **INSTALL POWER SUPPLY ON DIN RAIL.** To mount the power supply on the rail insert one end of both clips under one edge of the rail, then snap the other end of the two clips into place (see Figure 2A).

**REMOVING POWER SUPPLY FROM DIN RAIL.** With power off, disconnect wires from power supply. While grasping the power supply with one hand, insert a screwdriver in the area shown in Figure 2B and apply leverage towards the left as shown in Figure 2B to disengage each clip from the rail. Where mounting clips are close together, it may be necessary to apply leverage with two screwdrivers simultaneously.



**FIGURE 3. INSTALLING CLIPS ON POWER SUPPLY**

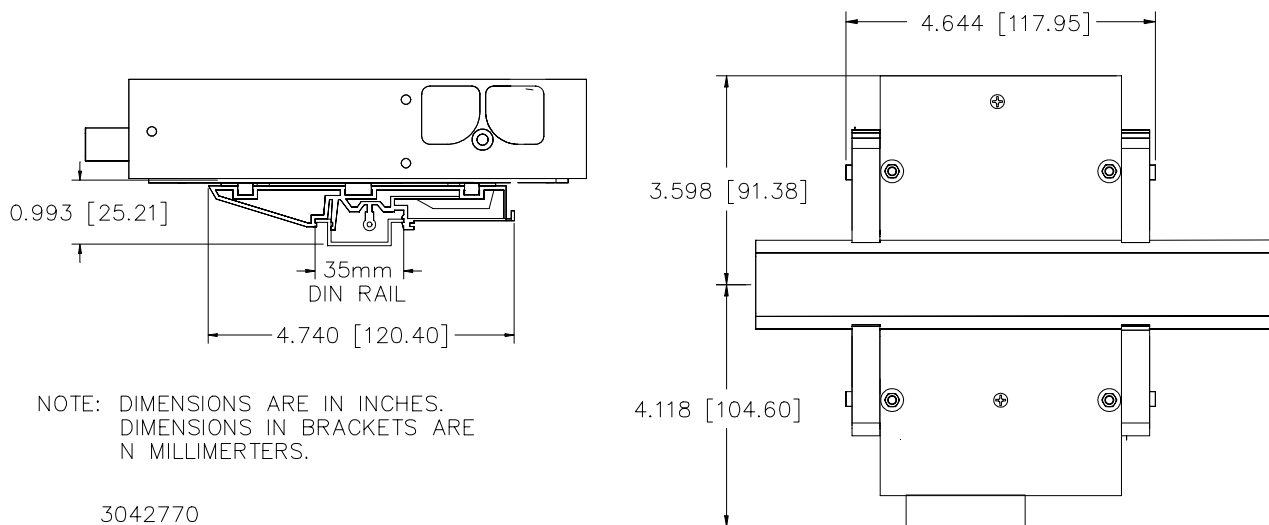

**FIGURE 4. POWER SUPPLY WITH KIT INSTALLED, OUTLINE DIMENSIONS**